

*Biarritz*



Ardoise

Cendre

Cognac

Écru

Mélange

40x40 . 16"x16" 20x40 . 8"x16"  
20x20 . 8"x8" . 10x10 . 4"x4"





# Biarritz

Sulle coste sabbiose di Biarritz un tempo salutate dal passaggio delle balene atlantiche, sorgono monumenti e scorci di grande eleganza. Il fascino delle onde marine che ne accarezzano le spiagge, l'hanno trasformata nella California dell'Europa, luogo prediletto per il surf e la vita di mare. Con il suo stile ricercato sempre attento alle mode e alle tendenze, Biarritz, fulcro di una mondanità e un jet set per nulla scontati, ispira una collezione di pavimenti e rivestimenti pensata per vestire d'eleganza la dolce vita contemporanea. Delicate texture che mescolano geometrie a elementi floreali perfettamente abbinabili fra loro, accompagnano le superfici di questa collezione, per riportare negli spazi tutta la bellezza della pietra. L'ampia gamma di formati modulari e la ricchezza dei colori consentono soluzioni decorative di grande impatto visivo, rendendo Biarritz la soluzione perfetta per personalizzare con pavimenti e rivestimenti, ambienti interni e spazi esterni.

*On the sandy coasts around Biarritz, sometimes visited by passing Atlantic whales, there are monuments and views of great elegance. The appeal of the ocean waves pounding onto the beaches has transformed it into Europe's California, and a favourite resort for surfing and seaside living. With its classy style and a constant eye kept on fashions and the latest trends, Biarritz, pinnacle of sophistication and home to a jet set to be reckoned with, inspires a collection of floors and walls devised to clothe this contemporary, laid-back lifestyle with elegance. Delicate textures mixing geometrical designs with floral elements that match each other to perfection are to be found on the surfaces in this collection, to bring back all the beauty of stone to the surroundings. The wide range of modular sizes and the richness of the colours enable decorative solutions of great visual impact to be achieved, making Biarritz the ideal solution to customize the floors and walls of indoor and outdoor areas.*

*Les côtes sableuses de Biarritz, autrefois saluées par le passage des baleines de l'Atlantique, offrent aux regards des monuments et des vues d'une grande élégance. Le charme des vagues caressant ses plages en ont fait la Californie de l'Europe, un lieu de prédilection des surfeurs et des amateurs de mer. Avec son style recherché, attentif aux modes et aux tendances, Biarritz, cœur d'une mondanité et d'une jet-set souvent imprévisibles, a été source d'inspiration pour une collection de revêtements sol et mur, conçue pour donner de l'élégance à la « dolce vita » contemporaine. De délicates textures, qui mêlent géométries et éléments floraux faciles à coordonner, accompagnent les surfaces de cette collection, pour apporter dans les espaces toute la beauté de la pierre. La vaste gamme de formats modulaires et la richesse des coloris permettent des solutions décoratives au grand impact visuel, et font de Biarritz la solution idéale pour personnaliser les espaces intérieurs et extérieurs grâce aux revêtements de sol et de mur.*

*An der sandigen Küste von Biarritz, die einst von den Walfischen des Atlantischen Ozeans beimgesucht wurden, befinden sich höchst elegante Monumente und Ausblicke. Die charmanten Wellen, die die Strände streicheln, haben den Ort zum europäischen Kalifornien gemacht, einen für den Surfsport und das Strandleben bevorzugten Ort. Dank seines anspruchsvollen Stils, der stets auf Moden und Trends achtet, hat Biarritz als mondäner Mittelpunkt eines ganz und gar nicht abgedroschenen Jet Set eine Boden- und Wandverkleidungskollektion für eine elegante Ausstattung der kontemporären ‚Dolce Vita‘ inspiriert. Zarte Texturen, die Geometrien mit perfekt untereinander kombinationsfähigen Blumenelementen mischen, begleiten die Oberflächen dieser Kollektion, um die volle Schönheit von Stein wieder in die Räume zu schaffen. Das umfangreiche Sortiment modularer Formate und die satten Farben ermöglichen höchst eindrucksvolle Dekorationen und machen aus Biarritz die perfekte Lösung für die Personalisierung von Böden und Wänden, Innen- und Außenbereichen.*

*На песчаных берегах Биаррица, которые в свое время приветствовали проплывавшие мимо киты, высятся памятники и открываются элегантные виды. Очарование морских волн, ласкающих пляжи, превратило его в европейскую Калифорнию - наилучшее место для серфинга и жизни на море. Благодаря своему изысканному стилю, который всегда внимателен к моде и к ее тенденциям, Биарриц, настоящий центр светской жизни и место притяжения элиты общества, вдохновляет собой коллекцию напольной и облицовочной плитки, задуманной для элегантного оформления современной сладкой жизни. Нежная текстура, смешивающая отлично сочетающиеся друг с другом геометрию и цветочные элементы, украшает поверхности этой коллекции, воспроизводя в пространствах всю красоту камня. Большая гамма модульных форматов и изысканность цветов позволяют получать декоративные решения с сильным зрительным эффектом, превращая Biarritz в идеальное решение для индивидуального оформления интерьеров и наружных пространств при помощи полов и облицовки стен.*









Écru

Waikiki Écru 40x40 R11









# Écru

- < Écru 40x40 RII 
- < Elemento ad "L" RII 
- < Battiscopa 8x40
- > Écru 20x20 RII 











- < Écru 10x10
- < Decoro Paradise Écru s/6 10x10, 20x20
- < Pezzi speciali Écru
- > Écru 20x20









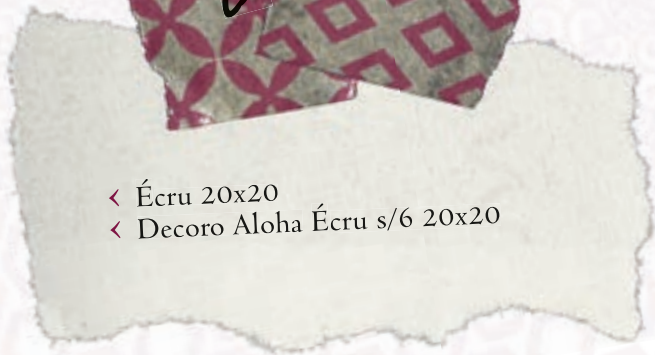

- < Écru 20x20
- < Decoro Aloha Écru s/6 20x20



# Cognac

- Waikiki Cognac 40x40, 20x20
- Cognac 40x40, 20x40, 20x20
- ✓ Waikiki Cognac 20x20

















# Cognac

- < Cognac 20x20 RII 
- < Elemento ad "L" Cognac RII 
- < Waikiki Cognac 20x20 RII 
- ✓ Waikiki Cognac 20x20 RII 

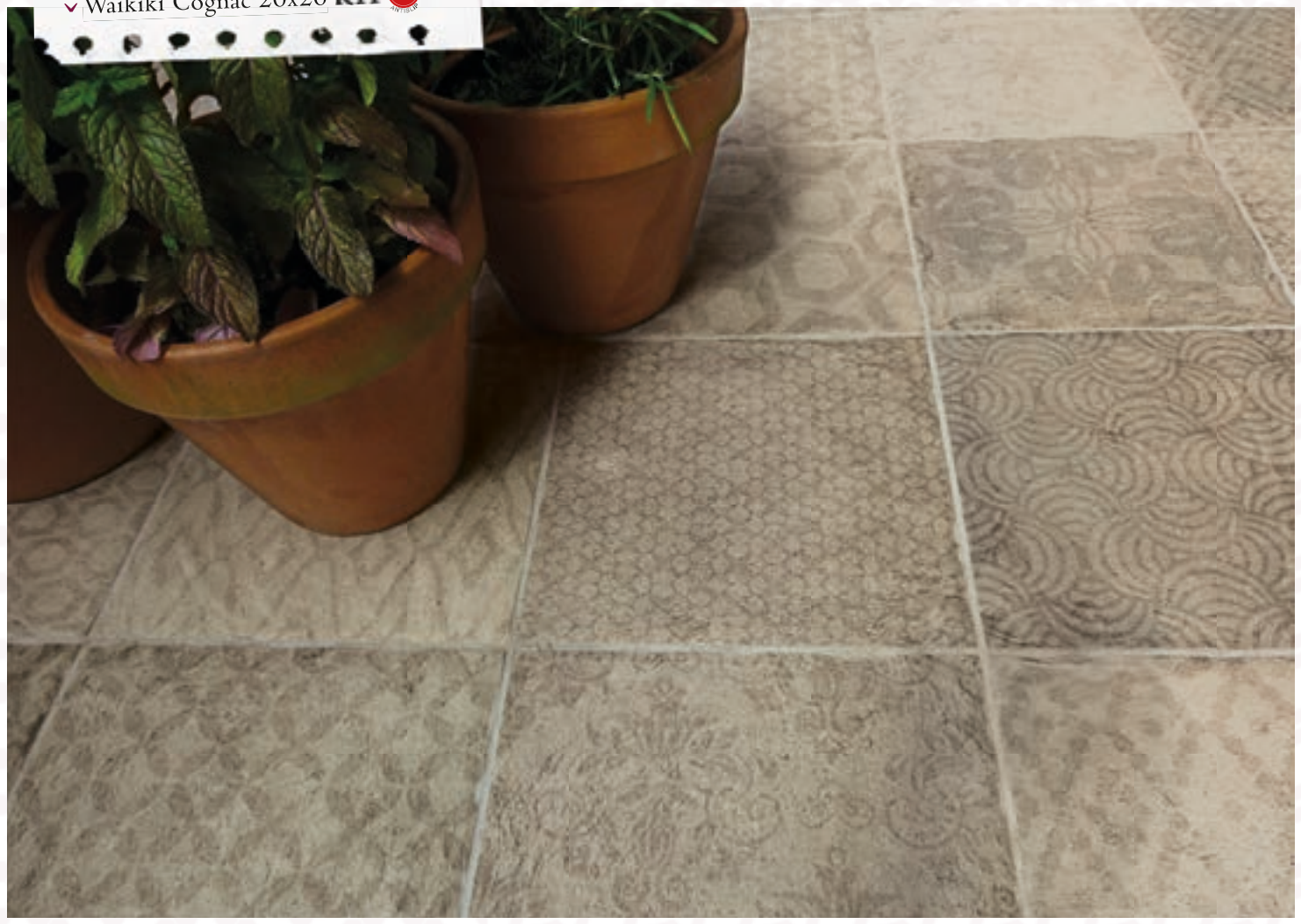









# Cognac

- < Cognac 40x40, 20x40, 20x20
- < Battiscopa Cognac 8x40
- > Cognac 40x40
- > Mosaico Waikiki Ecrú 30x30









# Cendre

< Waikiki Cendre 20x20

✓ Cendre 20x20 **R11** 











# Cendre

- < Cendre 10x10
- < Waikiki Cendre 10x10, 20x20
- < Pezzi speciali Cendre
- > Waikiki Cendre 20x20





# Cendre

- > Inserto Paradise Cendre C s/1 20x20
- > Inserto Paradise Cendre s/6 20x20
- ✓ Cendre 20x20
- ✓ Decoro Paradise Cendre A-B-C-D-E-F s/1 20x20
- ✓ Sigaro Biarritz Ardoise 2,5x20
- ✓ Ardoise 20x20















# Cendre

- < Cendre 40x40, 20x20, 10x10
- < Decoro Aloha Cendre s/6  
10x10, 20x20











*Ardoise*

- < Ardoise 20x40 RII 
- < Mosaico spacco Ardoise 30x40 RII 
- > Ardoise 20x20 RII 









# Ardoise

- < Waikiki Ardoise 20x20, 10x10
- < Ardoise 20x20, 10x10
- ✓ Ardoise 20x20 **R11** 







# Ardoise

- ^ Waikiki Ardoise 20x20
- > Ardoise 40x40, 20x40, 20x20
- ✓ Waikiki Ardoise 20x20













*Mélange*

< Mélange 40x40, 20x40, 20x20 RII 

▶ Mélange 20x20 RII 











# Mélange

- < Mélange 40x40, 20x40, 20x20
- ┆ Mélange 20x20, 10x10
- ┆ Decoro Aloha Mélange s/6 20x20, 10x10











# Biarritz

## colori

Colours  
Couleurs  
Lieferbar  
ЦВЕТА

## caratteristiche tecniche

technical features  
caractéristiques techniques  
technische eigenscheften  
ТЪХНИЧЪСКИЪ ХКРККТЪРИСТИКИ







# Écru

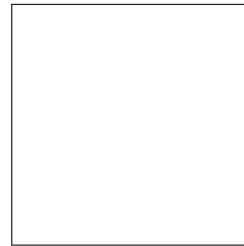

40x40 . 16"x16"  
40x40 . 16"x16" **R11**

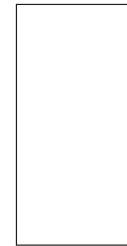

20x40 . 8"x16"  
20x40 . 8"x16" **R11**



20x20 . 8"x8"  
20x20 . 8"x8" **R11**



10x10 . 4"x4"

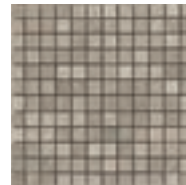

Mosaico Mix Beige  
(Écru, Cognac)  
30x30 - 12"x12"  
(2,2x2,2 - 7/8"x7/8")



Mosaico Mix Beige  
(Écru, Cognac)  
30x30 - 12"x12"  
(5x5 - 2"x2")



Mosaico Spacco **R11**  
30x40 - 12"x16"  
(7,5x7,5 - 3"x3")

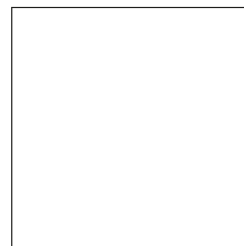

40x40 . 16"x16"  
40x40 . 16"x16" **R11**

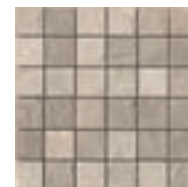

Mosaico Waikiki Écru  
30x30 - 12"x12"  
(5x5 - 2"x2")



20x20 . 8"x8"  
20x20 . 8"x8" **R11**



10x10 . 4"x4"

# waikiki Écru



40x40-16"x16". 20x40-8"x16". 20x20-8"x8". 10x10-4"x4"

# Cognac

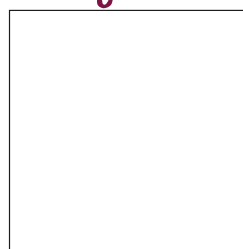

40x40 . 16"x16"  
40x40 . 16"x16" **R11**



20x40 . 8"x16"  
20x40 . 8"x16" **R11**



20x20 . 8"x8"  
20x20 . 8"x8" **R11**



10x10 . 4"x4"

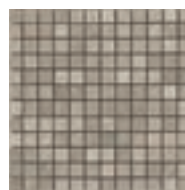

Mosaico Mix Beige  
(Écru, Cognac)  
30x30 - 12"x12"  
(2,2x2,2 - 7/8x7/8)



Mosaico Mix Beige  
(Écru, Cognac)  
30x30 - 12"x12"  
(5x5 - 2"x2")



Mosaico Spacco **R11**   
30x40 - 12"x16"  
(7,5x7,5 - 3"x3")

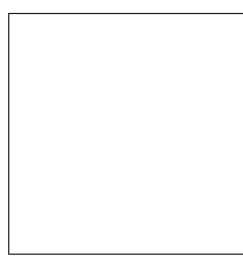

40x40 . 16"x16"  
40x40 . 16"x16" **R11**



20x20 . 8"x8"  
20x20 . 8"x8" **R11**



10x10 . 4"x4"

# waikiki Cognac





# Cendre

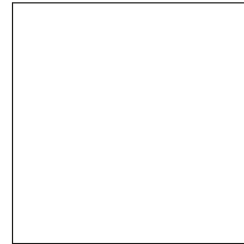

40x40 . 16"x16"  
40x40 . 16"x16" **R11**



20x40 . 8"x16"  
20x40 . 8"x16" **R11**

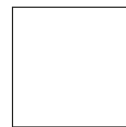

20x20 . 8"x8"  
20x20 . 8"x8" **R11**



10x10 . 4"x4"

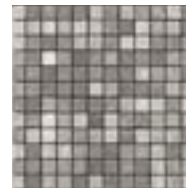

Mosaico Mix Grigio  
(Ardoise, Cendre)  
30x30 - 12"x12"  
(2,2x2,2 - 7/8"x7/8")

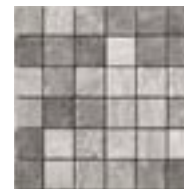

Mosaico Mix Grigio  
(Ardoise, Cendre)  
30x30 - 12"x12"  
(5x5 - 2"x2")



Mosaico Spacco **R11**   
30x40 - 12"x16"  
(7,5x7,5 - 3"x3")

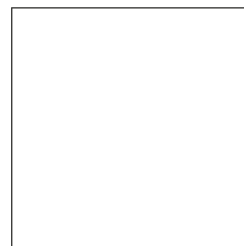

40x40 . 16"x16"  
40x40 . 16"x16" **R11**



Mosaico Waikiki Cendre  
30x30 - 12"x12"  
(5x5 - 2"x2")



20x20 . 8"x8"  
20x20 . 8"x8" **R11**



10x10 . 4"x4"

# waikiki Cendre



40x40-16"x16". 20x40-8"x16". 20x20-8"x8". 10x10-4"x4"

# Ardoise

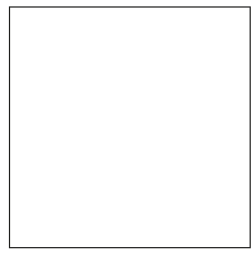

40x40 . 16"x16"  
40x40 . 16"x16" **R11**

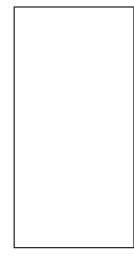

20x40 . 8"x16"  
20x40 . 8"x16" **R11**

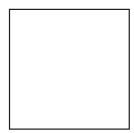

20x20 . 8"x8"  
20x20 . 8"x8" **R11**



10x10 . 4"x4"

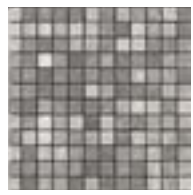

Mosaico Mix Grigio  
(Ardoise, Cendre)  
30x30 - 12"x12"  
(2,2x2,2 - 7/8"x7/8")

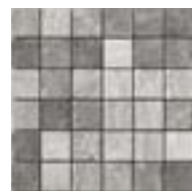

Mosaico Mix Grigio  
(Ardoise, Cendre)  
30x30 - 12"x12"  
(5x5 - 2"x2")



Mosaico Spacco **R11**  
30x40 - 12"x16"  
(7,5x7,5 - 3"x3")

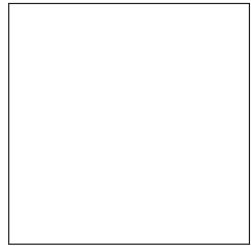

40x40 . 16"x16"  
40x40 . 16"x16" **R11**

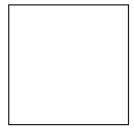

20x20 . 8"x8"  
20x20 . 8"x8" **R11**



10x10 . 4"x4"

# waikiki Ardoise



# Biarritz



## Mélange

composto da:  
Cendre, Écru

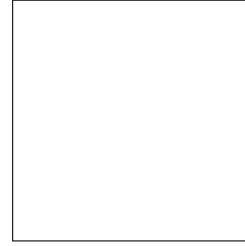

40x40 . 16"x16"  
40x40 . 16"x16" **R11**

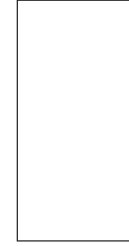

20x40 . 8"x16"  
20x40 . 8"x16" **R11**

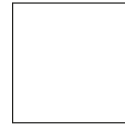

20x20 . 8"x8"  
20x20 . 8"x8" **R11**



10x10 . 4"x4"

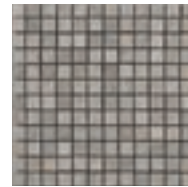

Mosaico Mélange  
30x30 - 12"x12"  
(2,2x2,2 - 7/8"x7/8")

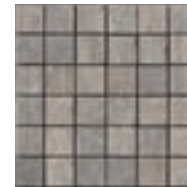

Mosaico Mélange  
30x30 - 12"x12"  
(5x5 - 2"x2")



Mosaico Spacco **R11**  
30x40 - 12"x16"  
(7,5x7,5 - 3"x3")

## Decori . Decors. Décors. Dekore. Декоры

### River



Mosaico River Ash  
30x30 - 12"x12"  
spessore 8,5 mm



Fascia River Ash  
10x30 - 4"x12"  
spessore 8,5 mm



Mosaico River Beige  
30x30 - 12"x12"  
spessore 8,5 mm



Fascia River Beige  
10x30 . 4"x12"  
spessore 8,5 mm

### Biarritz



Sigaro Biarritz  
Ardoise  
2,5x20 . 1 1/16"x8"



Sigaro Biarritz  
Cognac  
2,5x20 . 1 1/16"x8"

## Imballaggi

Packing - Emballage - Verpackung . Упаковка

	BOX			PALLET	
	PC	SQM	KGS	BOXES	SQM
40x40 . 16"x16"	7	1,12	29,30	48	53,76
20x40 . 8"x16"	14	1,12	29,30	48	53,76
20x20 . 8"x8"	22	0,88	20,60	54	47,52
10x10 . 4"x4"	60	0,60	14,70	72	43,20



40x40-16"x16". 20x40-8"x16". 20x20-8"x8". 10x10-4"x4"

**Pezzi Speciali** . Trims . Pièces Spéciales . Formstücke . Специальные изделия .

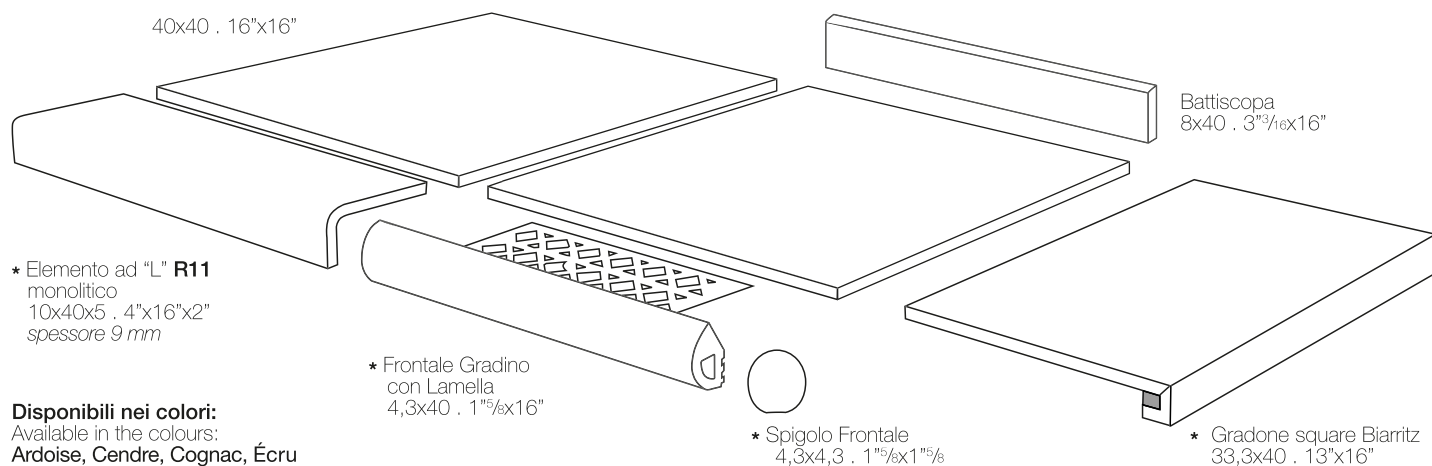

**Disponibili nei colori:**

Available in the colours:

Ardoise, Cendre, Cognac, Écru



## Pezzi Speciali 10x10

Trims . Pièces Spéciales . Formstücke . Специальные изделия .

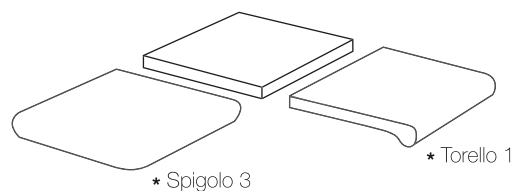

**Disponibili nei colori:**

Available in the colours:

Ardoise, Cendre, Cognac, Écru

\* Disponibile anche nel colore Mélange, solo su richiesta.

Available on Mélange only request.





# Decori , Decors, Décors, Dekore, Декоры

## paradise

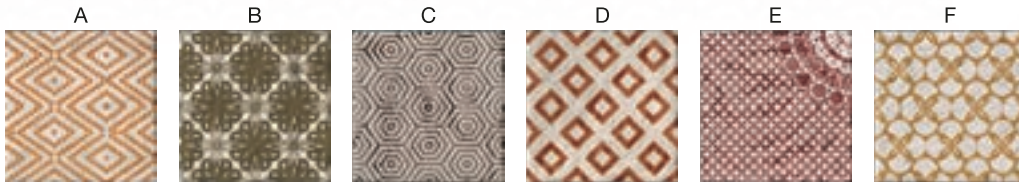

Inserto Paradise Écru A/B/C/D/E/F s/1  
20x20 . 8"x8"

Inserto Paradise Écru s/6  
20x20 . 8"x8"



Inserto Paradise Écru s/6  
10x10 . 4"x4"

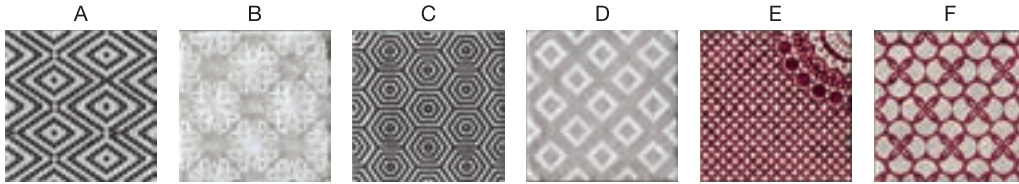

Inserto Paradise Cendre A/B/C/D/E/F s/1  
20x20 . 8"x8"

Inserto Paradise Cendre s/6  
20x20 . 8"x8"



Inserto Paradise Cendre s/6  
10x10 . 4"x4"

## Aloha

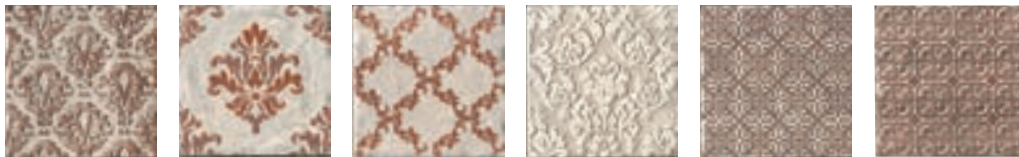

Inserto Aloha Écru s/6  
20x20 . 8"x8"



Inserto Aloha Écru s/6  
10x10 . 4"x4"

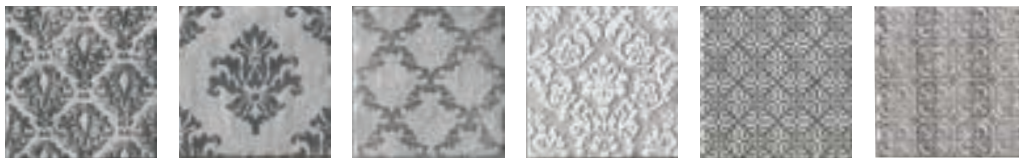

Inserto Aloha Cendre s/6  
20x20 . 8"x8"

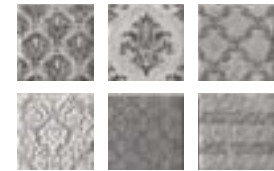

Inserto Aloha Cendre s/6  
10x10 . 4"x4"

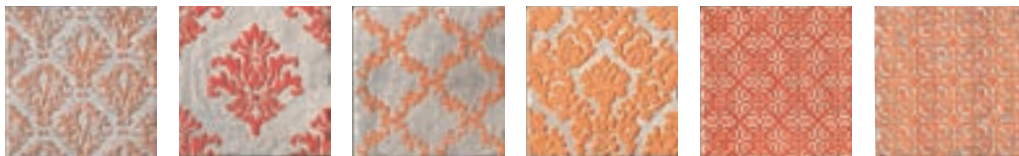

Inserto Aloha Mélange s/6  
20x20 . 8"x8"



Inserto Aloha Mélange s/6  
10x10 . 4"x4"



## Schemi di posa

Laying sketch . Schémas de pose . Modulverlegungsbeispiele . Схемы Укладки



\*



### \* MODULARE ALOHA ÉCRU (1 Mq. Nominale)

Écru 10x10 = 26 pzz  
Écru 20x20 = 11 pzz  
Inserto Aloha Écru s/6 20x20 = 6 pzz  
Inserto Aloha Écru s/6 10x10 = 6 pzz

### \* MODULARE ALOHA CENDRE (1 Mq. Nominale)

Cendre 10x10 = 26 pzz  
Cendre 20x20 = 11 pzz  
Inserto Aloha Cendre s/6 20x20 = 6 pzz  
Inserto Aloha Cendre s/6 10x10 = 6 pzz

### \* MODULARE ALOHA MÉLANGE (1 Mq. Nominale)

10x10 = 26 pzz  
20x20 = 11 pzz  
Inserto Aloha Mélange s/6 20x20 = 6 pzz  
Inserto Aloha Mélange s/6 10x10 = 6 pzz

### \* Solo per rivestimento

Fixing for wall only  
Pose que pour le revêtement mural  
Nur fuer die Wandklebung geeignet  
Композиция только для укладки на стену



### MODULARE PARADISE ÉCRU (1 Mq. Nominale)

Écru 10x10 = 26 pzz  
Écru 20x20 = 11 pzz  
Inserto Paradise Écru s/6 20x20 = 6 pzz  
Inserto Paradise Écru s/6 10x10 = 6 pzz

### MODULARE PARADISE CENDRE (1 Mq. Nominale)

10x10 = 26 pzz  
20x20 = 11 pzz  
Inserto Paradise Cendre s/6 20x20 = 6 pzz  
Inserto Paradise Cendre s/6 10x10 = 6 pzz



### MODULARE WAIKIKI (1 Mq. Nominale)

(nei colori: Ardoise, Cendre, Cognac, Écru)  
10x10 = 26 pzz  
20x20 = 11 pzz  
Inserto Waikiki s/6 20x20 = 6 pzz  
Inserto Waikiki s/6 10x10 = 6 pzz

### MODULARE WAIKIKI MÉLANGE (1 Mq. Nominale)

10x10 = 26 pzz  
20x20 = 11 pzz  
Inserto Waikiki s/6 20x20 = 6 pzz  
Inserto Waikiki s/6 10x10 = 6 pzz



## Schemi di posa

Laying sketch . Schémas de pose . Modulverlegungsbeispiele . Схемы Укладки

### MODULARE 10B

1 - 20x20 14,3%  
2 - 20x40 28,6%  
3 - 40x40 57,1%

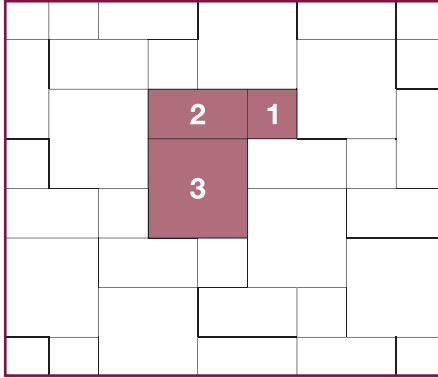
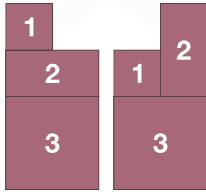

### MODULARE 17

1 - 20x20 25%  
2 - 20x40 25%  
3 - 40x40 50%

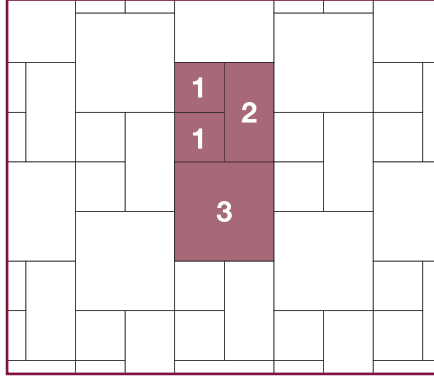
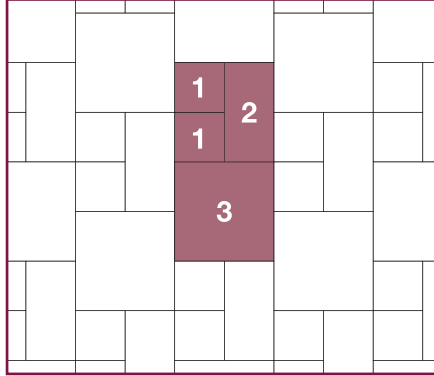

### MODULARE 18

1 - 20x20 11,1%  
2 - 20x40 44,45%  
3 - 40x40 44,45%

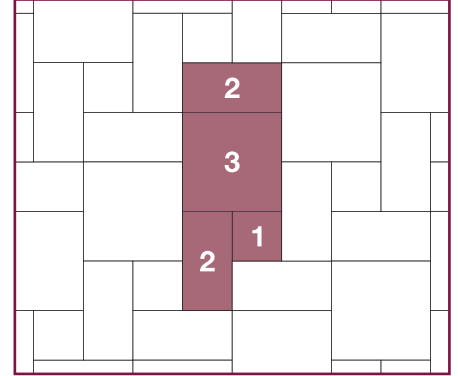
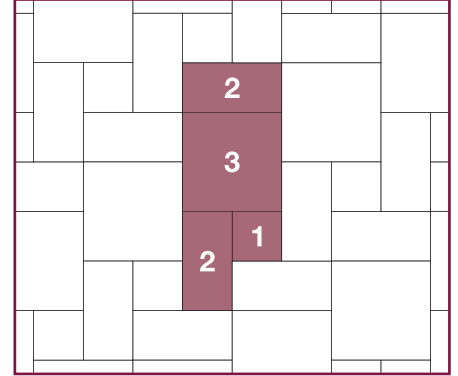

### MODULARE 19

1 - 20x20 11,1%  
2 - 20x40 44,45%  
3 - 40x40 44,45%

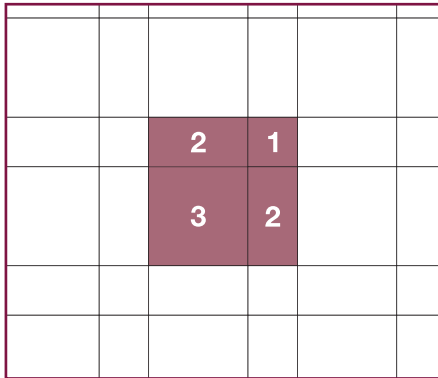
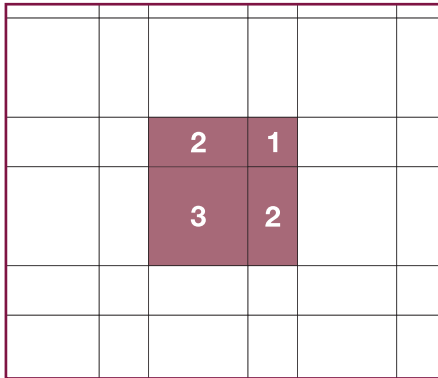

### MODULARE 20

2 - 20x40 50%  
3 - 40x40 50%

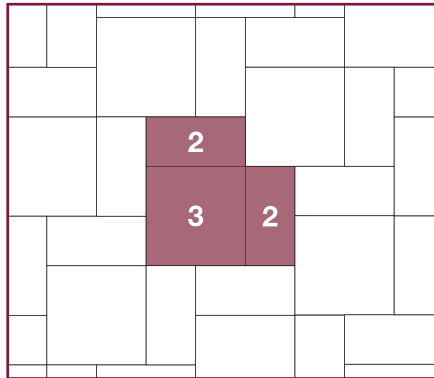
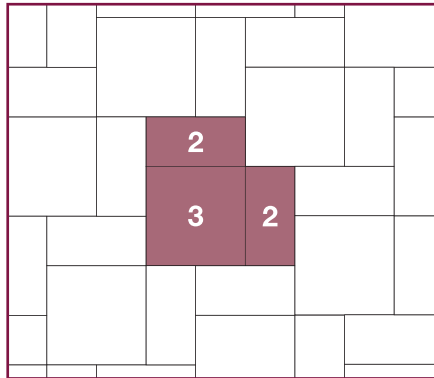

### MODULARE 21

1 - 20x20 20%  
3 - 40x40 80%

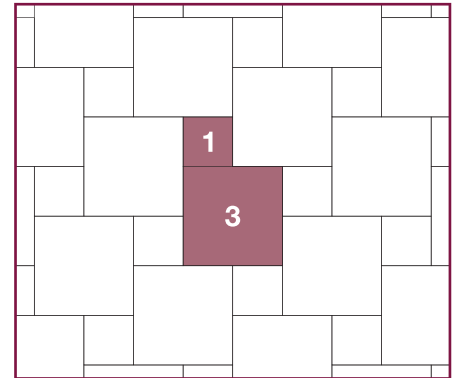
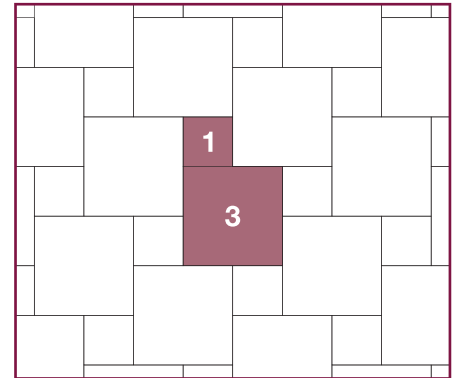

### MODULARE 22

3 - 40x40 94,1%  
4 - 10x10 5,9%

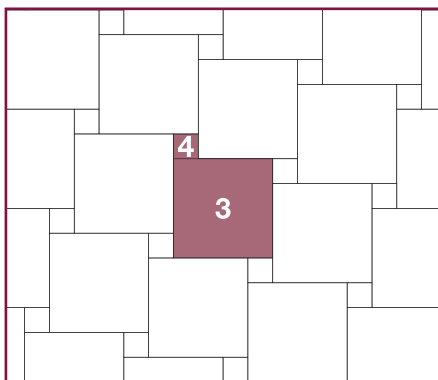
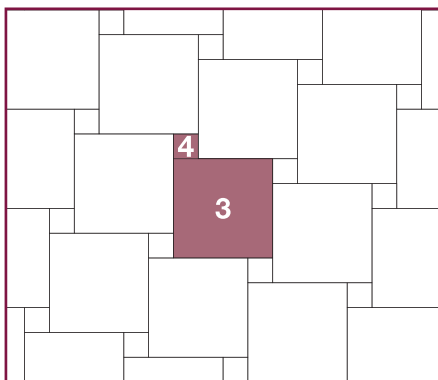

### MODULARE 23

1 - 20x20 11%  
2 - 20x40 89%

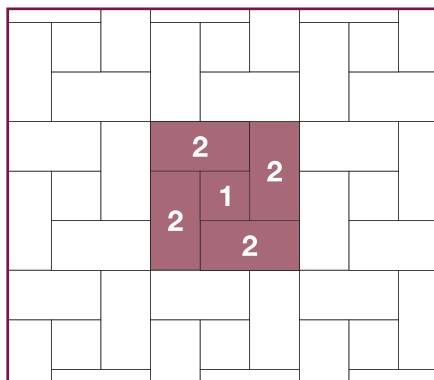
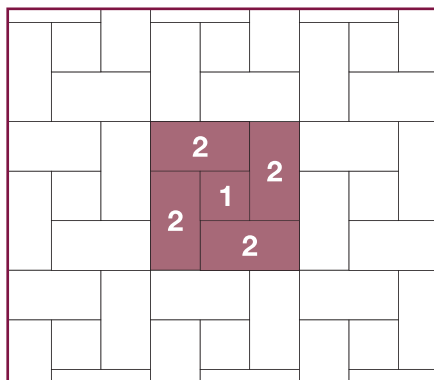

### MODULARE 24

1 - 20x20 20%  
2 - 20x40 80%

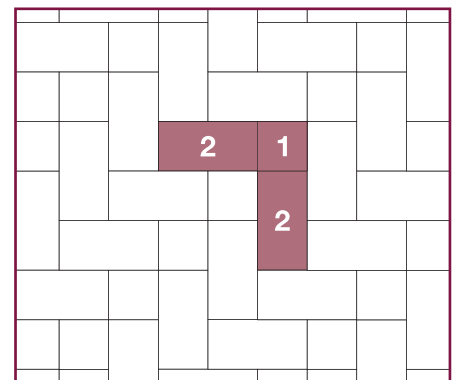
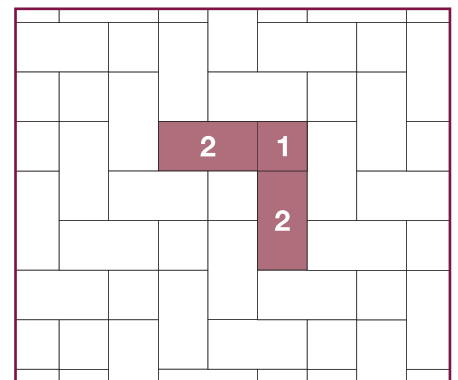



<b>CARATTERISTICHE TECNICHE GRES FINE PORCELLANATO SMALTATO CIR - ISO 13006 Bla GL</b> TECHNICAL FEATURES CIR GLAZED FINE PORCELAIN STONWARE - ISO 13006 Bla GL - CARACTÉRISTIQUES TECHNIQUES GRÈS CÉRAME FIN ÉMAILLÉ CIR - ISO 13006 Bla GL TECHNISCHE EIGENSCHAFTEN CIR GLASIERTES FEINSTEINZEUG - ISO 13006 Bla GL - ТЕХНИЧЕСКИЕ ХАРАКТЕРИСТИКИ ТОНКОГО ГЛАЗУРОВАННОГО ФАРФОРОВОГО КЕРАМОГРАНИТА CIR - ISO 13006 Bla GL			
	<b>Proprietà fisico-chimiche</b> Physical chemical properties / Propriétés physico chimiques Physisch chemische Eigenschaften / Физико химические свойства	<b>Metodo di prova</b> Standard of test / Norme du test Testnorm / Метод испытаня	<b>Valore medio</b> Mean value / Valeur moyenne Mittelwert / Среднее значение
	Dimensioni Dimensions Dimensions Abmessungen Размеры		
	Lunghezza e larghezza Length and width Longueur et largeur Länge und Breite Длина и ширина	W  10 test	± 0,6% max  ± 0,5% max
	Spessore Thickness Epaisseur Stärke Толщина	ISO 10545 - 2	± 5% max
	Rettilinearità degli spigoli Straightness of sides Rectitude des arêtes Kantengeradheit Прямолинейность кромок		± 0,5% max
	Ortogonalità Rectangularity Orthogonalité Rechtwinkligkeit Ортогональность		± 0,6% max
	Planarità Surface flatness Planéité Ebenflächigkeit Плоскостность	ISO 10545-2  ASTM C 485	± 0,5% max  Warpage diagonal/edge ± 0,4%
	Variazioni di tono Shade variations Variations de nuances Tonvariationen Вариация оттенка		 FORTE STONALIZZAZIONE FORTSÄTTNING AV FÄRGER EFFET RENFORCE DES ACCENTUE STARK FÄRBERÖKAD ГОРЯЧАЯ РАДИКА ТОНА
	Assorbimento d'acqua Water absorption Absorption d'eau Wasseraufnahme Водопоглощение	ISO 10545 - 3	$E \leq 0,5\%$ Bla GL
	Resistenza al gelo Frost resistance Résistance au gel Frostbeständigkeit Морозостойкость	ISO 10545 - 12	Ingelivo Frost proof Résistant au gel Frostsicher Морозостойкий
	Resistenza agli sbalzi termici Resistance to thermal shock Résistance aux écarts de température Temperaturwechselbeständigkeit Стойкость к тепловым перепадам	ISO 10545 - 9	Resistente Résistant Widerstandsfähig Устойчивый
	Resistenza al cavillo di piastrelle smaltate Crazing resistance of glazed tiles Résistance à la tréssailure des carreaux émaillés Haarrissbeständigkeit der glasierten Fliesen Стойкость глазурованной плитки к кракелюру	ISO 10545 - 11	Resistente Résistant Widerstandsfähig Устойчивый
	Resistenza della superficie (scala MOHS) Scratch hardness (MOHS scale) Dureté de la surface (échelle MOHS) Oberflächenhärte (MOHS skala) Поверхностная прочность по (шкале Мооса)	EN 101	Mohs 8
	Resistenza alla abrasione della superficie di piastrelle smaltate Resistance to surface abrasion of glazed tiles Résistance à l'abrasion de la surface des carreaux émaillés Widerstand gegen Abrieb der Oberfläche der glasierten Fliesen Стойкость глазурованной плитки к поверхностному истиранию	ISO 10545 - 7	Classe 4 Class 4 Classe 4 Gruppe 4 Klasse 4
	Resistenza ai prodotti chimici di uso domestico Resistance to household chemicals Résistance aux produits chimiques ménagers Widerstand gegen Haushaltsreineriger Стойкость к бытовым химикатам	ISO 10545 - 13	Classe GA Class GA Classe GA Gruppe GA Klasse GA
	Resistenza agli acidi e alle basi a bassa concentrazione Resistance to low concentrations of acids and bases Résistance aux acides et aux bases à faible concentration Widerstand gegen schwach konzentrierten Säuren und Laugen Стойкость к низкоконцентрированным кислотам и щелочам		Classe GLA Class GLA Classe GLA Gruppe GLA Klasse GLA
	Resistenza alle macchie di piastrelle smaltate Resistance to stains of glazed tiles Résistance aux taches des carreaux émaillés Widerstand gegen Fleckenbildner der glasierten Fliesen Стойкость глазурованной плитки к образованию пятен	ISO 10545 - 14	Classe 5 Class 5 Classe 5 Gruppe 5 Klasse 5
	Resistenza alla flessione Bending strength Résistance à la flexion Biegezugfestigkeit Прочность на изгиб	Modulo di rottura - Modulus of rupture Module de rupture - Bruchmodul - Модуль жесткости  Carico di rottura - Breaking of rupture Charge de rupture - Bruchkraft - С-фшсцц вш кщсгккф	ISO 10545 - 4  R $\geq 35$ N/mm <sup>2</sup>  S $\geq 1300$ N
	Caratteristiche antidrucciolo Anti-slip properties Caractéristiques antidérapantes Rutschhemmende Eigenschaft Характеристики устойчивости к скольжению	DIN 51130  DIN 51097  B.C.R.A. REP. CEC. 6/81  ASTM C 1028  DCOF	R10 - R11  Classe C Class CC Classe CC Gruppe C Klasse C  R10: $\mu \geq 0,40$ R11: $\mu \geq 0,74$  R11: DRY: $\mu > 0,70$ - WET: $\mu > 0,70$ R10: DRY: $\mu > 0,70$ - WET: $\mu > 0,60$  $\mu > 0,42$

Prova eseguita su: 20x20 cm e 20x20 cm waikiki / Test carried out on: 20x20 cm end 20x20 cm waikiki / Essai effectué sur: 20x20 cm et 20x20 cm waikiki / Getestet auf: 20x20 cm und 20x20 cm waikiki  
 Испытание произведено на: 20x20 см и Waikiki 20x20 см



Per informazioni relative ai dati tecnici su marcatura CE vedere il sito [www.cir.it](http://www.cir.it)  
 Please refer to our website [www.cir.it](http://www.cir.it) for technical information related to CE labeling  
 Pour tout renseignement sur l'avis technique de la marque CE veuillez consulter le site [www.cir.it](http://www.cir.it)  
 Informationen bezüglich technischer Daten zur Beschriftung CE entnehmen Sie unserer Website [www.cir.it](http://www.cir.it)  
 Технические данные маркировки ЕС смотреть сайт [www.cir.it](http://www.cir.it)

Prima Edizione: Luglio 2013  
 PROGETTO: Omniadvert  
 COORDINAMENTO: Ufficio Marketing Cir  
 FOTO: Foto Mussatti  
 FOTOELABORAZIONI: Ufficio Marketing Cir - Digital Design  
 STAMPA: Arbe Industrie Grafiche  
 CREDITS: Arredo bagno Cerasa - [www.cerasa.it](http://www.cerasa.it)  
 Arredamento Agora Forme d'arredo - [www.agorasrl.biz](http://www.agorasrl.biz)

Thank to:







**SERENISSIMA CIR** S.p.A.  
INDUSTRIE  CERAMICHE 



sponsor **BOLOGNA F.C. 1909**

**Ceramica Cir**

Via A. Volta 23/25 - 42013 Casalgrande (RE) Italy  
Tel. +39-0522-998911 - Fax Italy +39-0522-998910 - Fax Export +39-0522-998930  
www.cir.it - e-mail: cir@cir.it - e-mail Italy: italia@cir.it - e-mail Export: export@cir.it  
**Serenissima Cir Industrie Ceramiche spa**  
Società Unipersonale  
www.serenissimacir.com

**DAL 1969**